

SPECIFICATIONS

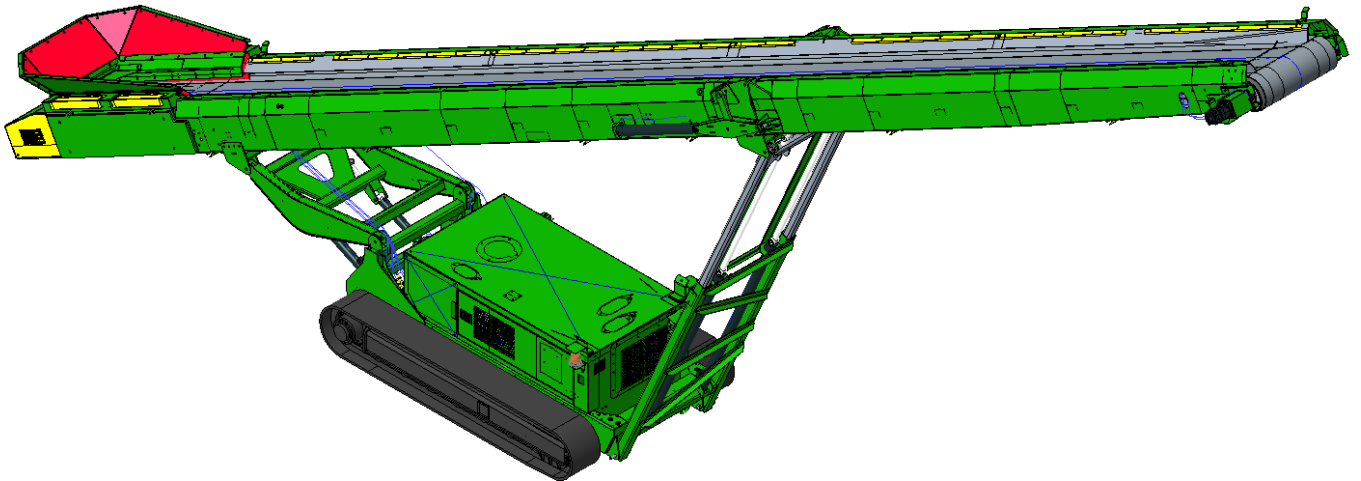
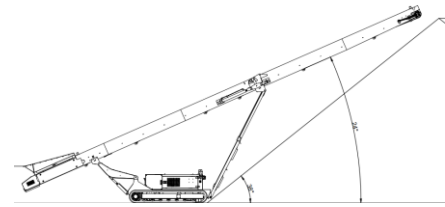

TS4065 V2 TRACK CONVEYOR

Optional equipment may be shown

**DESCRIPTION**

Designed to allow operators to stockpile/transfer material directly from mobile crushing and screening plants, this stacker offers the perfect solution to all your material handling needs. It offers the flexibility and mobility needed to ensure that the stockpiling process is as fast and efficient as possible, it eliminates the use of a loader and the double handling of materials.

The unit can also be containerized for transport, with minimal setup time, substantially reducing transport costs.

The TS4065 Track Conveyor comes with the following features as standard:

- Hydraulic folding heading section for transport minimizing setup time.
- Hydraulically adjustable discharge height up to 8.4 meters
- Hydraulically adjustable feed in height to compliment crushing and screening plants.
- 3.5 Meter tracks for superior maneuverability and stability.
- ISUZU 4LE1 TIER 3 36KW giving a rating of up to 450 TPH.
- Fuel efficient Hydraulics system.
- User Friendly Hydraulic Controls
- Feed boot hardox liners
- Heavy Duty Impact Bed

DIMENSIONS AND CAPACITIES

Length – working (Max)	18.2m (59'-10")
Height – working (Max)	8.4m (27'-8")
Length – transport	12.1m (39'-9")
Width – transport	2.34m (7'-8")
Height – transport	2.5m (8'-3")
Machine Weight	10,500kg Approx.
Maximum Production Rate	450TPH @ 23° angle
Max Product Size	150 MM (6") minus

MATERIALS

Materials include but are not limited to;

- Sand and Gravel
- Aggregates
- Compost
- Topsoil
- C and D waste
- Mulch
- Coal

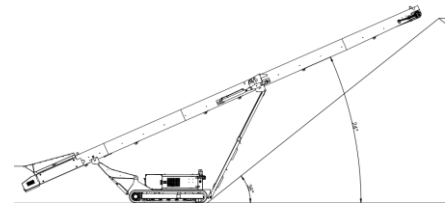
**CONVEYOR**

Belt width	1000mm (40")
Belt spec	3 Ply (400/3 5+1.5)
Scraper	Urethane scraper as standard
Pulley Adjuster	Standard Threaded Bar
Conveyor Idlers	45 Degree angle
Return Idlers	Self-Cleaning Rubber Disc
Conveyor motor	Single DANFOSS OMOV630
Drive Drum	350mm Ø with herringbone Lagging
Tail Drum	270mm Ø spoked drum
Max Belt Speed	3 M/Sec (165RPM)
Engine Speed	2600 RPM

Capacities

Hydraulic tank	285 L (75 US gal)
Diesel Tank	200 L (53 US gal)
Feed Boot Capacity	1.1M ³ (1.4 Yd ³)

OPTIONS INCLUDING BUT NOT LIMITED TO;

- Dual Power Drive.
- Feed boot Rubber Liners.
- Lift Axel Radial
- ISUZU 4LE2X 47.4 KW T4F (600-700 TPH)
- Head Scraper upgrade.
- Anti-Roll backs
- Rear Hydraulic Folding Jack legs
- Extended Feed boot with crash Box.
- Radio remote control Conveyor and setup functions.
- Heavy duty 4 ply belt
- Lift Axle Radial

SAFETY FEATURES

- External belt alignment points.
- External grease points.
- Engine safety shutdown systems.
- Full safety guarding for nip points.

TS4065 V2
February.2019.issue 001

