

SPECIFICATIONS

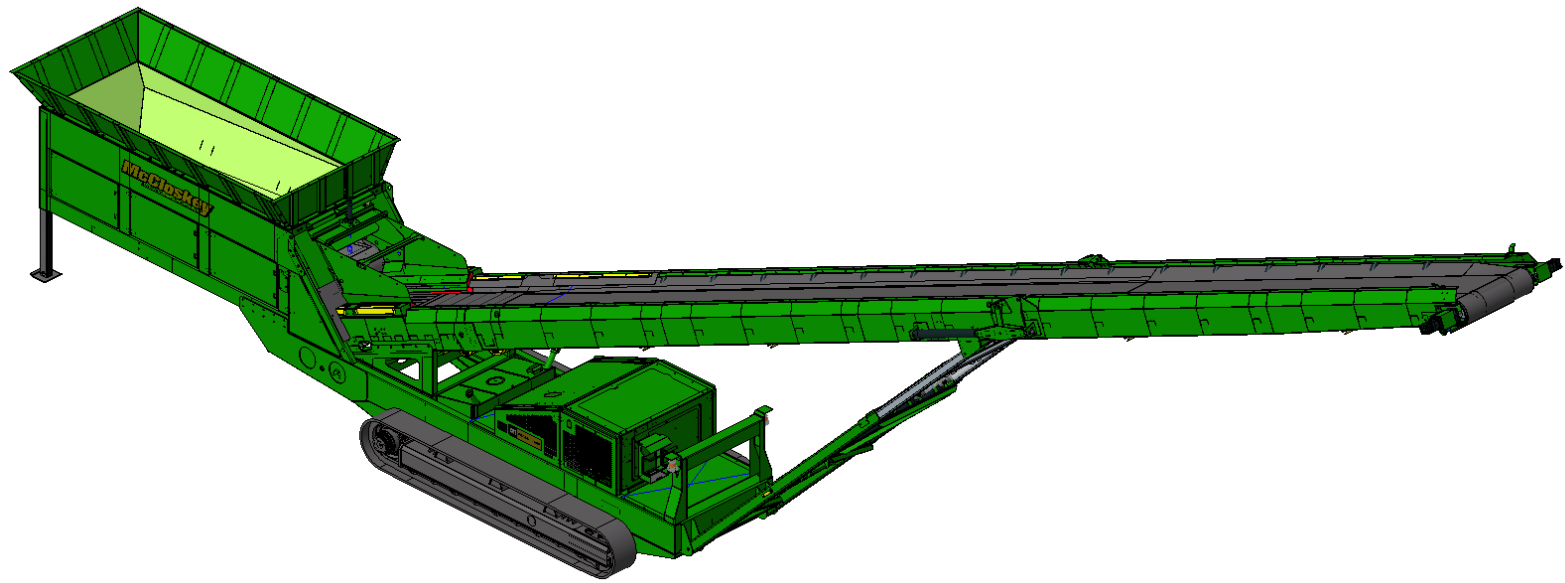

SF80 FEEDER CONVEYOR

Optional equipment may be shown

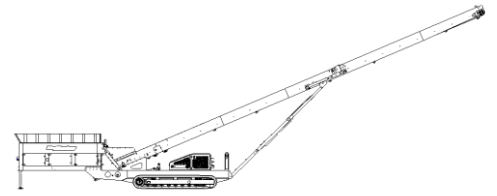

DESCRIPTION

The newly designed SF80 is McCloskey international's latest offering as a feeder stacker. It comprises of a large feeder hopper that transfers material onto an 80ft conveyor. Designed to allow operators to stockpile/transfer material it eliminates double handling of materials.

The unit can also be compacted for transport on one low loader for easy site to site transport.

The SF80 feeder Conveyor comes with the following features as standard:

- Dual hydraulic main drive system.
- Hydraulic folding heading section for transport minimizing setup time.
- Hydraulically adjustable discharge height up to 10 meters
- 4 Meter tracks for superior maneuverability and stability.
- CAT 4.4 100KW (127HP) LRC/Fixed speed giving a rating of up to 800 TPH.
- Fuel efficient Hydraulics system.
- User Friendly Hydraulic Controls
- Hopper extensions increasing capacity

DIMENSIONS AND CAPACITIES

Length – working (Max)	26.2m (86'-1")
Height – working (Max)	10m (32'-5")
Length – transport	19.4m (38'-8")
Width – transport	3.2m (10'-6")
Height – transport	3.4m (11'-1")
Over Hang - Transport	7.2m (23'-9")
Maximum Production Rate	800 MTPH (880 TPH)
Max Product Size	150MM (6") minus
Weight	24500KG Approx.
Hopper Capacity	13 M ³ (17 Yd ³)

MATERIALS

Materials include but are not limited to;

- Sand and Gravel
- Aggregates
- Compost
- Topsoil
- C and D waste
- Coal

FEED CONVEYOR

Belt width	1200mm (48")
Belt spec	Plain 500/3 6+3
Drive drum dia.	335mm (13.1")
Tail drum dia.	320mm (12.5")
Gearbox	Bonfig 805 W2

SF80

OCT.2018.issue 002

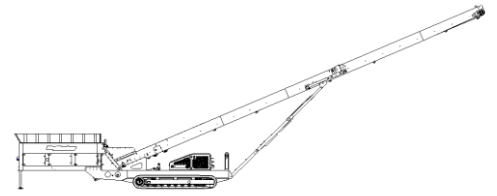

Motor	160cc motor
Flow rate	72.6 Lpm (19.2 US gpm)
Adjustable speed	YES
Maximum speed	18.75 rpm

CONVEYOR

Belt width	1200mm (48")
Belt spec	3 Ply (400/3 5+1.5)
Scraper	Urethane scraper as standard
Pulley Adjuster	Standard Threaded Bar
Conveyor Idlers	45 Degree angle
Return Idlers	Self-Cleaning Rubber Disc
Conveyor motor	Twin DANFOSS OMV630
Drive Drum	350mm Ø with Herringbone Lagging
Tail Drum	270mm Ø spoked drum

CAPACITIES

Hydraulic tank	516 L (136 US gal)
Diesel Tank	390 L (103 US gal)

OPTIONS INCLUDING BUT NOT LIMITED TO;

- Feed hopper hardox liners.
- Remote control tipping Grid
- Hydraulic flow gate from feeder.
- Live Head
- Head Scraper upgrade.
- Anti-Roll backs
- Rubber track Pads
- Hopper Bridge
- CAT 3.4 T4F 75KW (100HP)
- Radio remote tracking
- Radio remote start stop feeder (variable speed)
- Radio remote start stop main conveyor (variable speed)

SAFETY FEATURES

- External belt alignment points.
- External grease points.
- Engine safety shutdown systems.
- Full safety guarding for nip points.

SF80

OCT.2018.issue 002

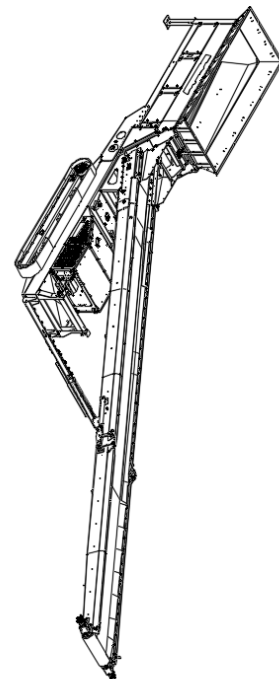
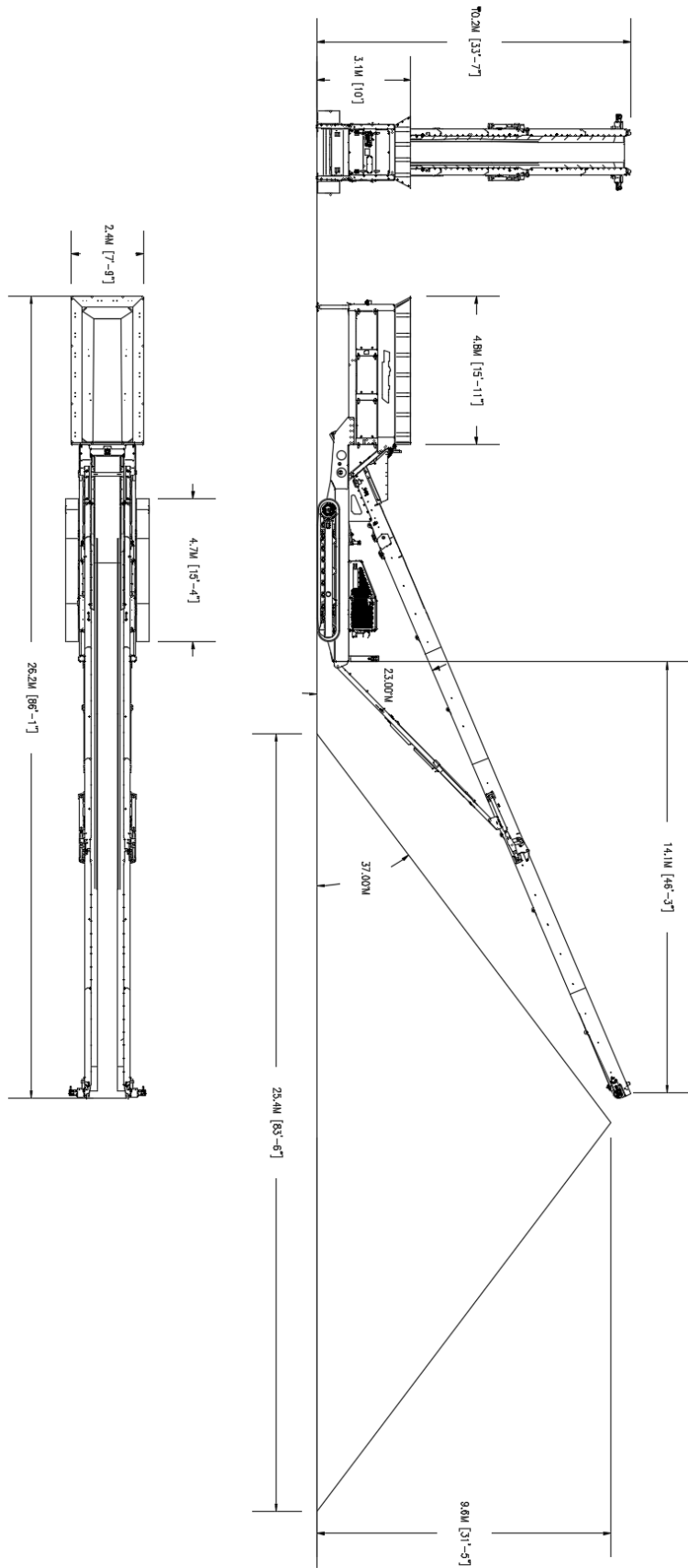
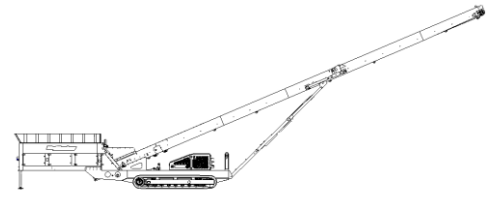

SF80

OCT.2018.issue 002

