



ROKBRO

Material Processing Equipment



PROCESS MORE RECOVER MORE BUILD PROFITABILITY



STATIC, MOBILE & MODULAR WASTE RECYCLING EQUIPMENT

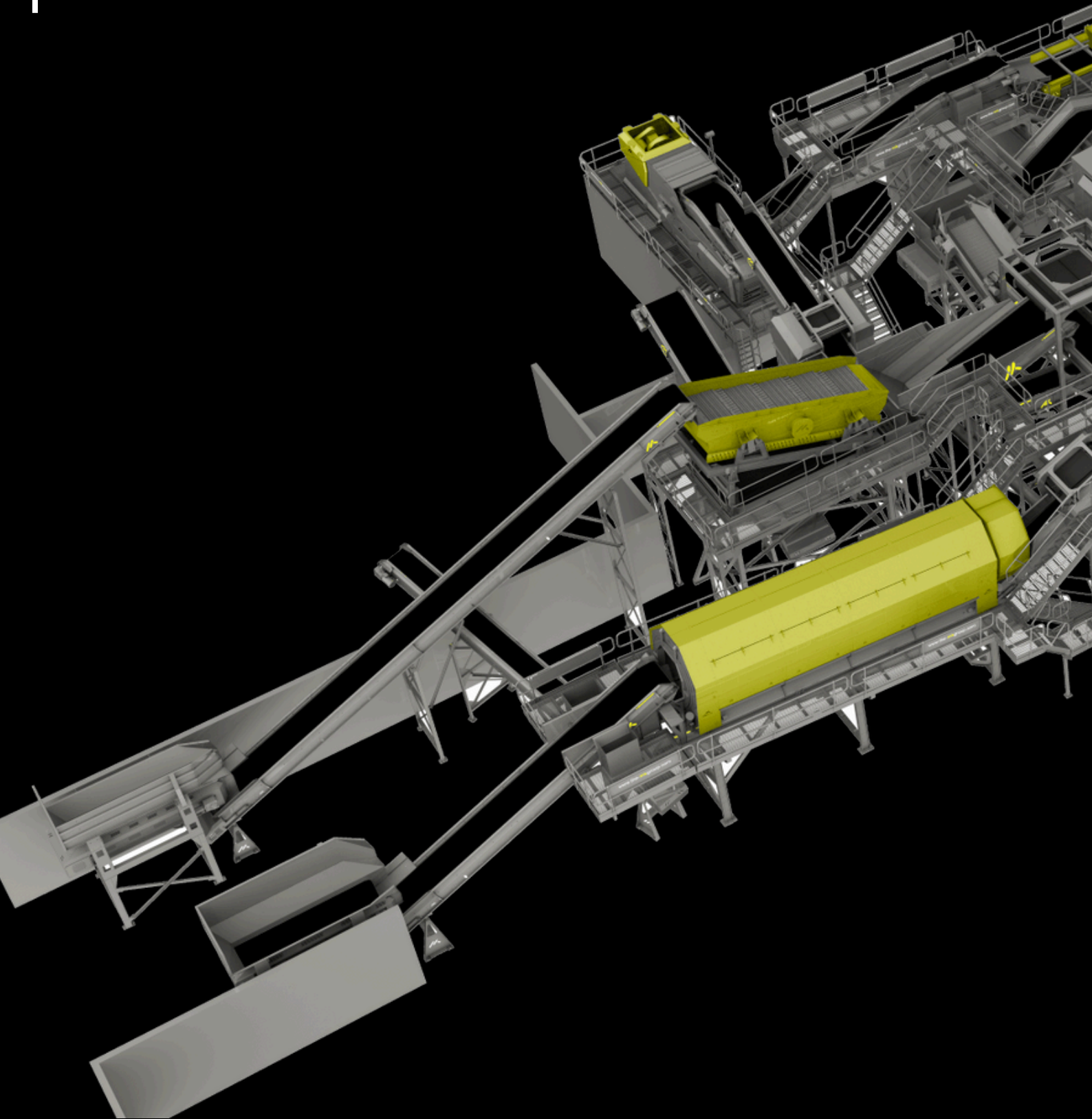

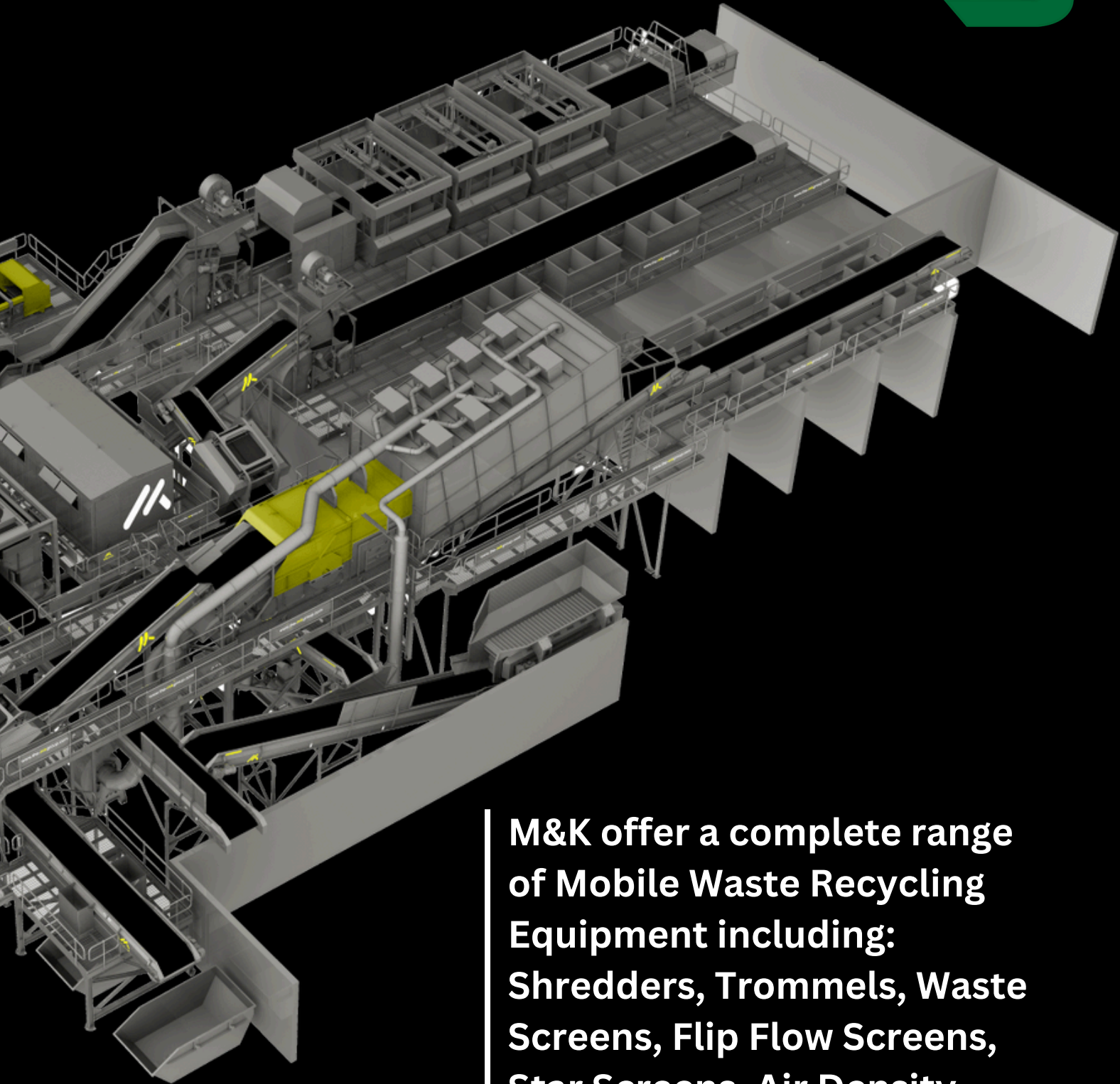

M&K offer a complete range of Mobile Waste Recycling Equipment including: Shredders, Trommels, Waste Screens, Flip Flow Screens, Star Screens, Air Density Separators, Eddy Current Separators, Picking Stations and Conveyors.

Mobile Picking Stations

PS312M



MOBILE PICKING STATION

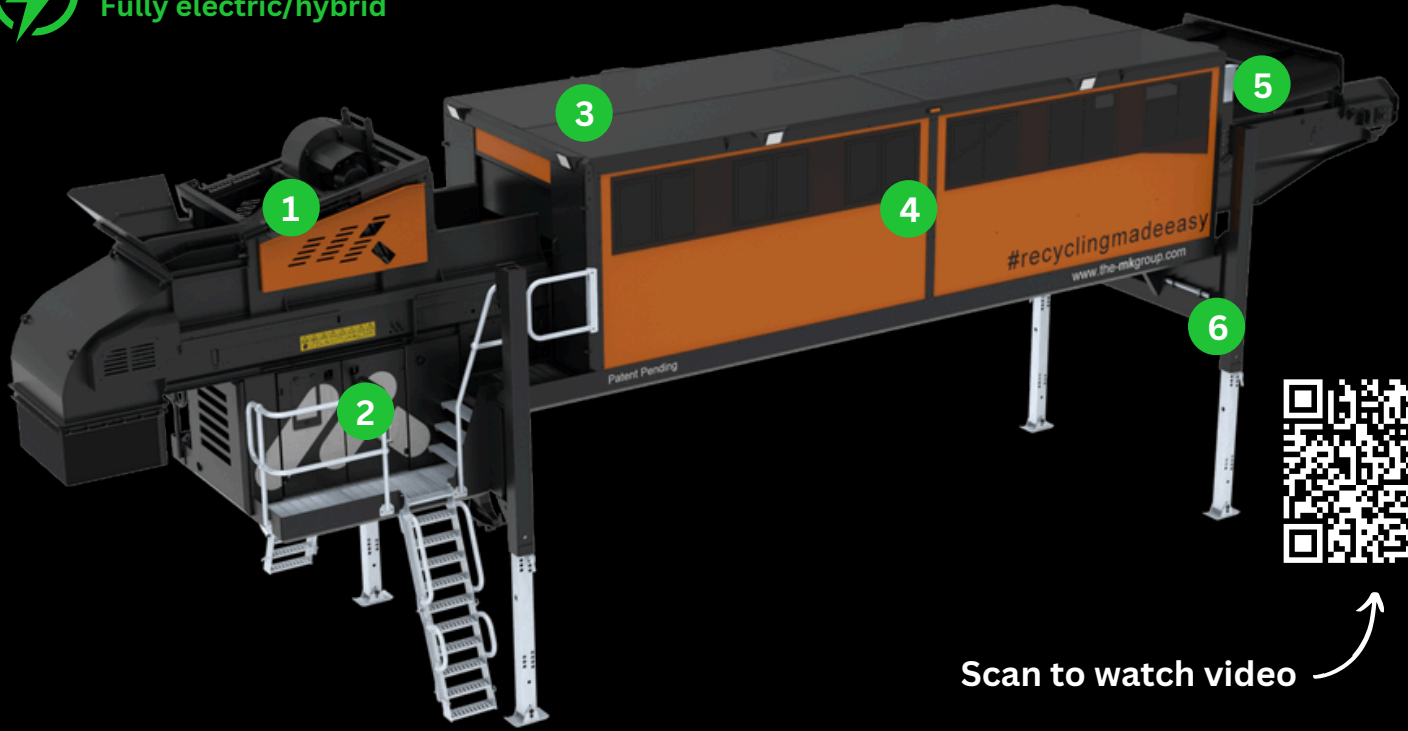
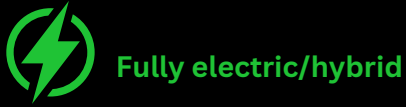

Scan to watch video



- 1** Air Separator
15Kw
Hydraulic In & Our
Hydraulic Out of Line
VSD
- 2** Powerpack
Dual Power
60kva Generator
30KW Hydraulic PowerPack
Touch Screen HMI
- 3** Picking Cabin
3 Bay
6 Chutes
Metal Construction
- 4** Picking Conveyor
1200mm
VSD
- 5** Magnet
Bi Directional
Height Adjustable
450 Gauss @ 300mm
- 6** Chassis
Hydraulic Jacklegs
Radio Control
Site Axle
Towbar



PS312W



MOBILE PICKING STATION (WHEELED)

 Fully electric/hybrid



Scan to watch video 

- 1** Air Separator
15Kw
Hydraulic In & Our
Hydraulic Out of Line
VSD
- 2** Powerpack
Dual Power
60kva Generator
30KW Hydraulic PowerPack
Touch Screen HMI
- 3** Picking Cabin
3 Bay
6 Chutes
Metal Construction
- 4** Picking Conveyor
1200mm
VSD
- 5** Magnet
Bi Directional
Height Adjustable
450 Gauss @ 300mm
- 6** Chassis
Hydraulic Jacklegs
Radio Control
Site Axle
Towbar





PS212T



TRACKED 2 BAY PICKING STATION



Fully electric/hybrid



Scan to watch video



1 Feed Conveyor & Hopper
1200mm Chevron
Dual Drive
VSD

2 Powerpack
Dual Power
60kva Generator
30KW Hydraulic PowerPack
Touch Screen HMI

3 Air Separator
15Kw
Hydraulic In & Out
Hydraulic Out of Line
VSD

4 Picking Cabin
2 Bay
4 Chutes (Side)
Metal Construction

5 Picking Conveyor
1200mm
VSD

6 Magnet
Bi Directional
Height Adjustable
450 Gauss @ 300mm

7 Discharge Conveyor
1200mm Chevron



Density Separators

AS150T



TRACKED AIR DENSITY SEPARATOR HYBRID



Fully electric/hybrid

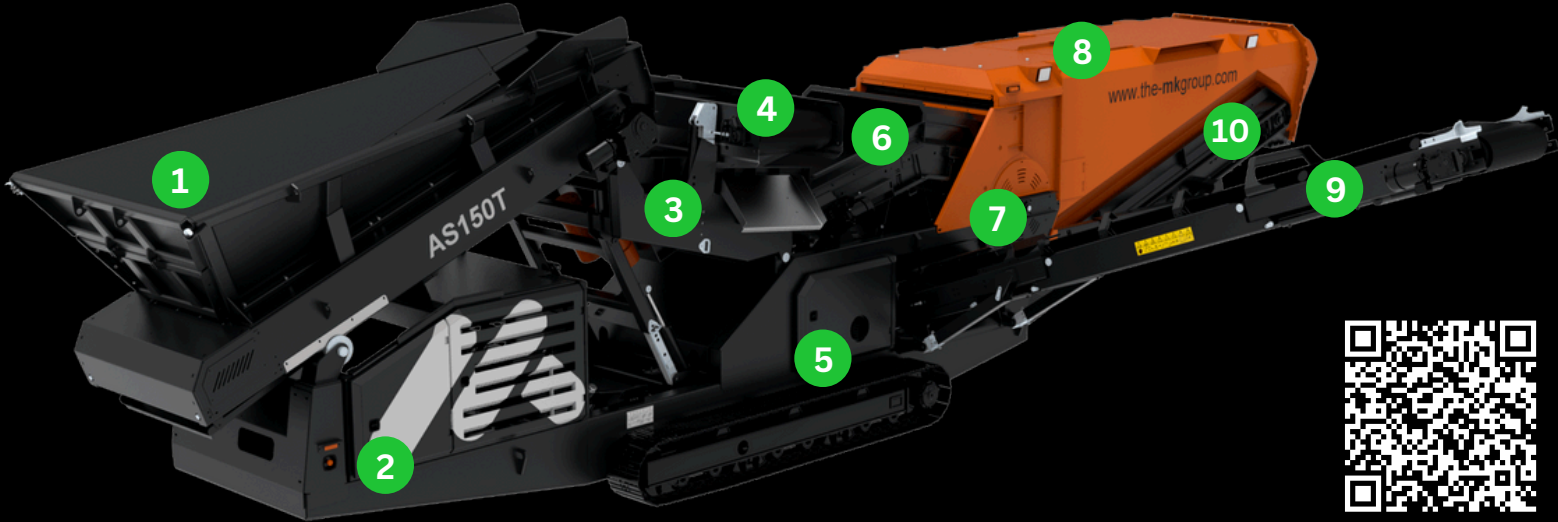

Scan to watch video



- 1 Feed conveyor & hopper**
1300mm chevron
Dual Drive
VSD
- 2 Powerpack**
Dual Power
60kva Generator
30kW Hydraulic PowerPack Touch
Screen HMI
- 3 Vibrating Feeder**
1400mm
Stainless Steel
Hyd Angle Adjustment Wear Plates
VSD
- 4 Magnet**
Bi Directional
Hydraulic Adjustment
(300mm Max)
- 5 Air Separation Module**
2 x 11kw Blowers Adjustable Nozzle
VSD
- 6 Accelerator Belt**
1500mm
Hydraulic Adjustment In Out | Up Down
VSD
- 7 Splitter Drum**
1800mm
VSD
- 8 Decompression Chamber**
Decompression Fan
VSD
- 9 Heavy Fraction Conveyor**
900mm Chevron
VSD
- 10 Lights Conveyor**
1200mm



AS150M



MODULAR AIR DENSITY SEPARATOR HYBRID

 Fully electric/hybrid

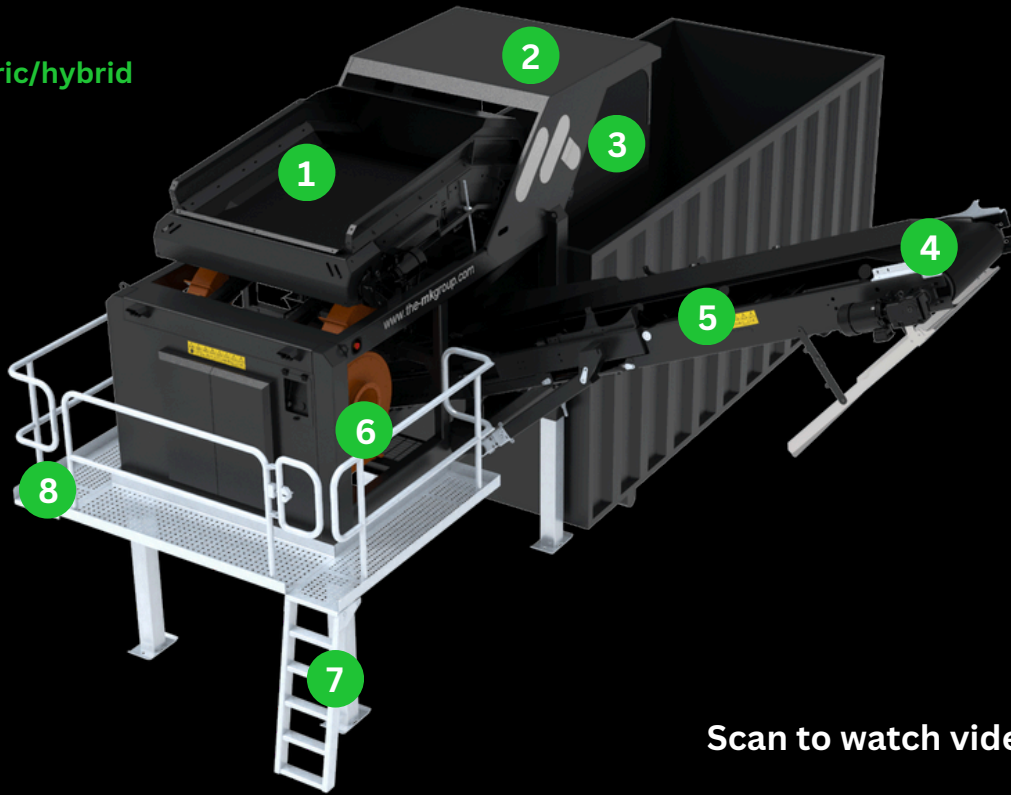

Scan to watch video 

- 1** Accelerator Conveyor
11500mm Wide
4Kw VSD
X-Y Hydraulic Adjustable
- 2** Splitter Drum
1650mm Wide
5.5kw VSD
- 3** Light Fraction
- 4** Optional Magnetic Headdrum
- 5** Heavy Fraction Conveyor
900mm Wide
4kw VSD
Hydraulic Folding
- 6** Air Separation Module
2 x 15kw High Pressure Blowers
- 7** Adjustable Legs
Manual (not hydraulic)
- 8** Walkways



Trommel

TS620T



TRACKED RECYLCING TROMMEL SCREEN HYBRID

Fully electric/hybrid

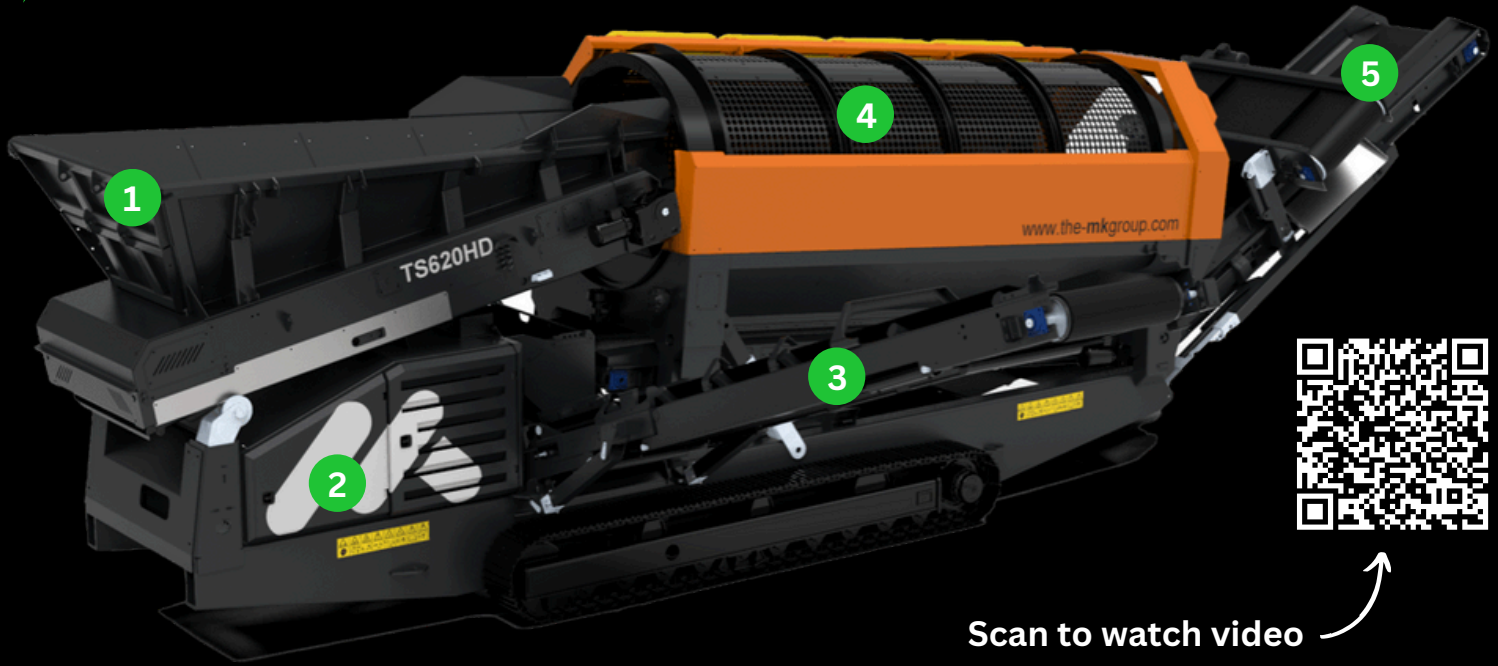

Scan to watch video

1 Feed conveyor & hopper
1300mm chevron
Dual Drive
VSD

2 Powerpack
Dual Power
60kva Generator
30kW Hydraulic PowerPack
Touch Screen HMI

3 Fines Conveyor
900mm
VSD

4 Trommel Screen
6000mm x 2000mm
Heavy Duty Welded Design
Bolt In Mesh
4 Wheel Drive - Hydraulic

5 Oversize Conveyor
1200mm Chevron
VSD

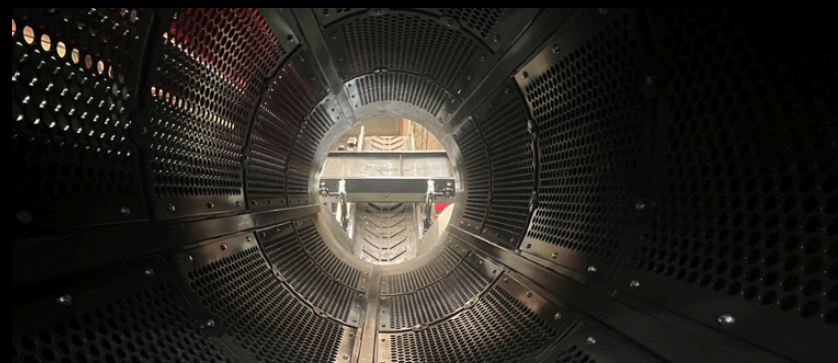

Helical Star Screen



HS210T

Tracked Helical Star Screen



Fully electric/hybrid



Scan to watch video 



Flip Flow Screen

RS514T



FLIP FLOW RECYCLING SCREEN

 Fully electric/hybrid

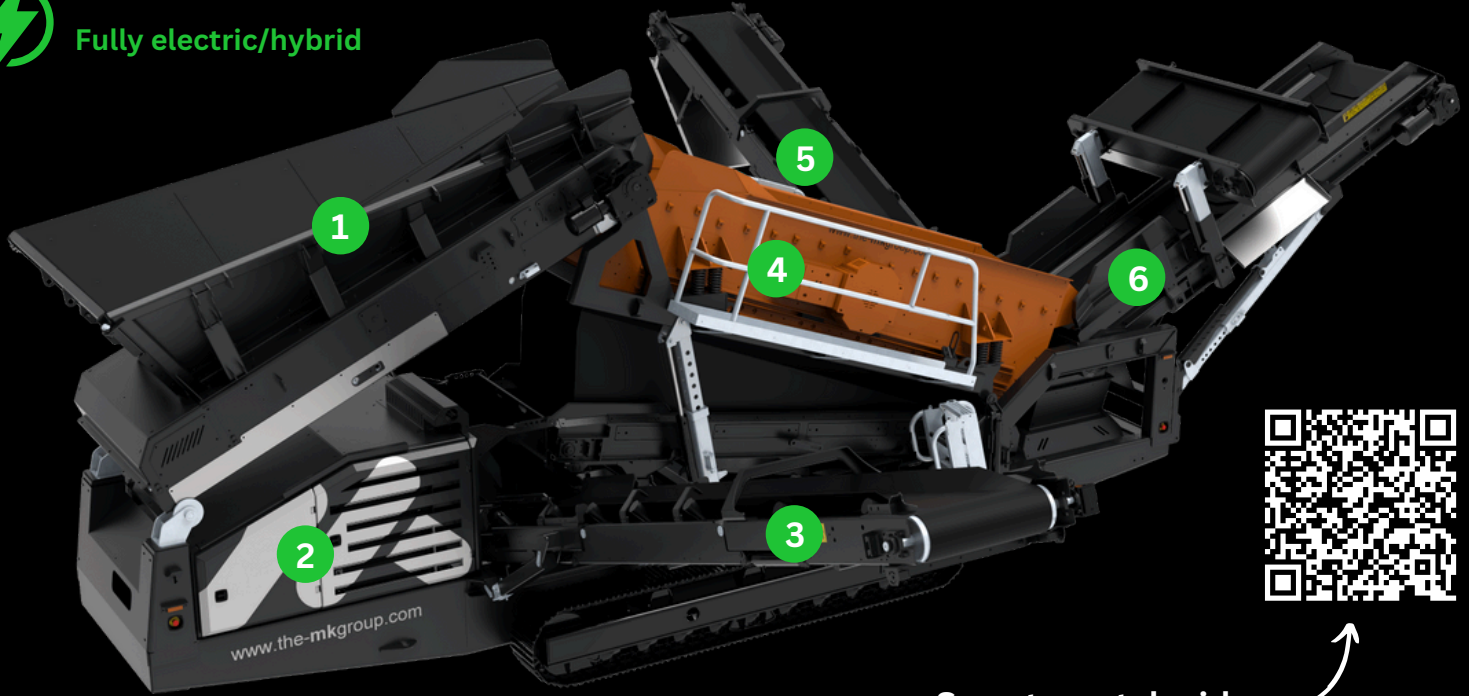

Scan to watch video 

1 Feed conveyor & hopper
1300mm chevron
Dual Drive
VSD

2 Powerpack
Dual Power
60kva Generator
30kW Hydraulic PowerPack
Touch Screen HMI

3 Fines conveyor
900mm
VSD

4 Recycling Screen
5000mm x 1400mm
3D Top Deck
Flip Flow Bottom Deck
Hydraulic Drive

5 Mid Size Conveyor
900mm
VSD

6 Oversize Conveyor
1200mm Chevron
VSD

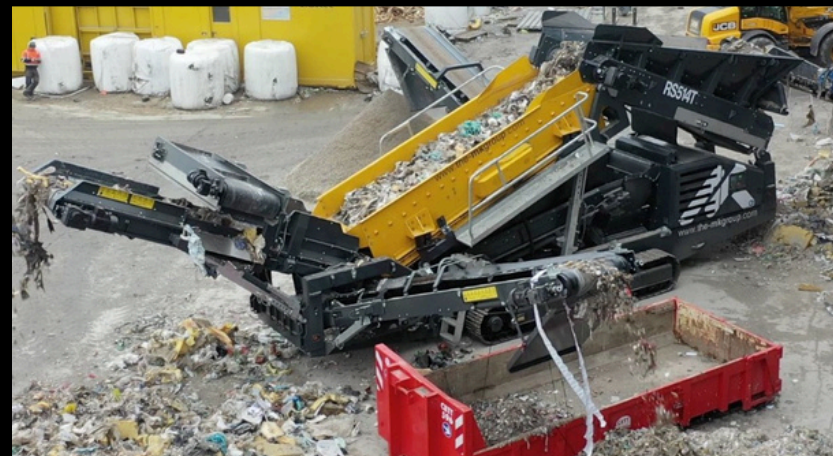

SERVICE

After sales service and support is a key focus of the Rokbro as we understand the need for your equipment to be operational and profitable. That is why we focus on long term relationships with our customers, to support them long after the initial sale. We have the technical experts to get your equipment back operational. Our objective is to work with you throughout the life cycle of your equipment by offering on-going support throughout the entire life of your machinery. In addition our Nationwide coverage of OEM trained field based engineers supported by a growing infrastructure of technical experts ensure that Rokbros after care support is unrivalled in our sector.



PARTS

While all our products are manufactured from high quality components, from time to time some parts may need replacing.

If that happens, you can be rest assured that replacement parts will be available to you on demand.

We hold a large stock of genuine replacement parts at our headquarters.

With a dedicated and vastly experienced spare parts team, our aim is to always get you up and running as fast as possible.





275 Fitzgerald Road, Drury 2577



sales@rokbro.co.nz



rokbro.co.nz

DISCOVER MORE

