



R70 PORTABLE SCREENER

The McCloskey® R70 delivers the versatile, heavy-duty configuration that is expected of the R-Series screeners, but can be transported easily and economically.

FEATURES

- ✓ 2.8m x 1.220m (9' x 4') heavy duty high energy 2 bearing 2 deck screenbox
- ✓ 97kW (130Hp) diesel engine
- ✓ Integrated hydraulic folding stockpiling conveyors
- ✓ Service standing room inside the powerpack
- ✓ Fast on-site setup time – 10 minutes
- ✓ Track mobile



The R70 is a perfect fit for contractors that require the ability to tackle large numbers of smaller heavy-duty construction, demolition, and remediation projects.

The R70 is built with the durability and screening performance that McCloskey International has built its reputation on, using high-quality components and the innovative McCloskey High Energy Screenbox.

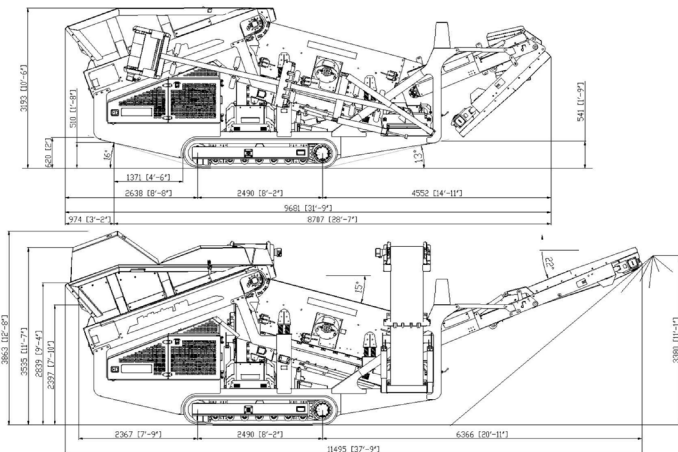

TECH SPECS

Engine	97kW (130 Hp)
Belt Feed Conveyor Width	1200mm (48")
Stockpile Height Tail Conveyor	3.38m (11' 1")
Stockpile Height Side Conveyor	3.56mm (11' 8")
Screenbox Dimensions	2.80m x 1.22m (9' x 4')
Screen Area Top & Bottom Deck	6.50 m ² (70 ft ²)

TRANSPORT

Transport Height	3.20m (10' 6")
Transport Length	9.68m (31' 9")
Transport Width	2.50m (8' 2.4")
Weight	15,400kgs (33,951 lbs)

OPTIONS

Heavy duty top deck finger screen | Bottom deck finger screen | Top deck punch plate screen | Bottom deck punch plate