

TESAB



1350T

HIGH PERFORMANCE IMPACT CRUSHER

The 1350T Impactor continues to bring high quality and high production capacity to Tesabs mobile impactor applications.

The 1350T has been designed with durability, power and ease of use in mind. New features include open chassis for ease-of-access, optional full length main conveyor or optional underpan under the crushing chamber conveyor, hydraulic adjustable magnet, and a new larger double deck prescreen for more efficient fines removal. Main and side conveyors are now wider to accommodate a larger volume of prescreen discharge material, and to allow for better discharge from the crushing chamber.

The 1350T's versatility and upgraded design makes it ideal for some of the toughest applications worldwide, including asphalt recycling, concrete recycling, rock crushing, construction and demolition.

FEATURES & BENEFITS

- 1200mm (48") diameter x 1350mm (53") wide Impactor
- 510Hp (380kW) engine
- Integrated hydraulic foldinghopper
- I-beam plate fabricated chassis construction
- Open chassis design for ease of maintenance
- Fast setup time
- Tracked
- Integrated hydraulic folding stockpiling conveyors.
- Vibrating feeder under crusher discharge

IMPACT CRUSHER

TESAB

8.9 yd³ (6.8m³) hopper features liners, hydraulic locking wedges, and side locking wedges that are easily operated from the ground.

The much larger crusher prescreen maximizes crusher efficiency and delivers screened product via a straight chute to a new wider 32" side conveyor.

New wider 55" (1400mm) main conveyor, giving large stockpile capacity. Conveyor lowers and raises hydraulically.

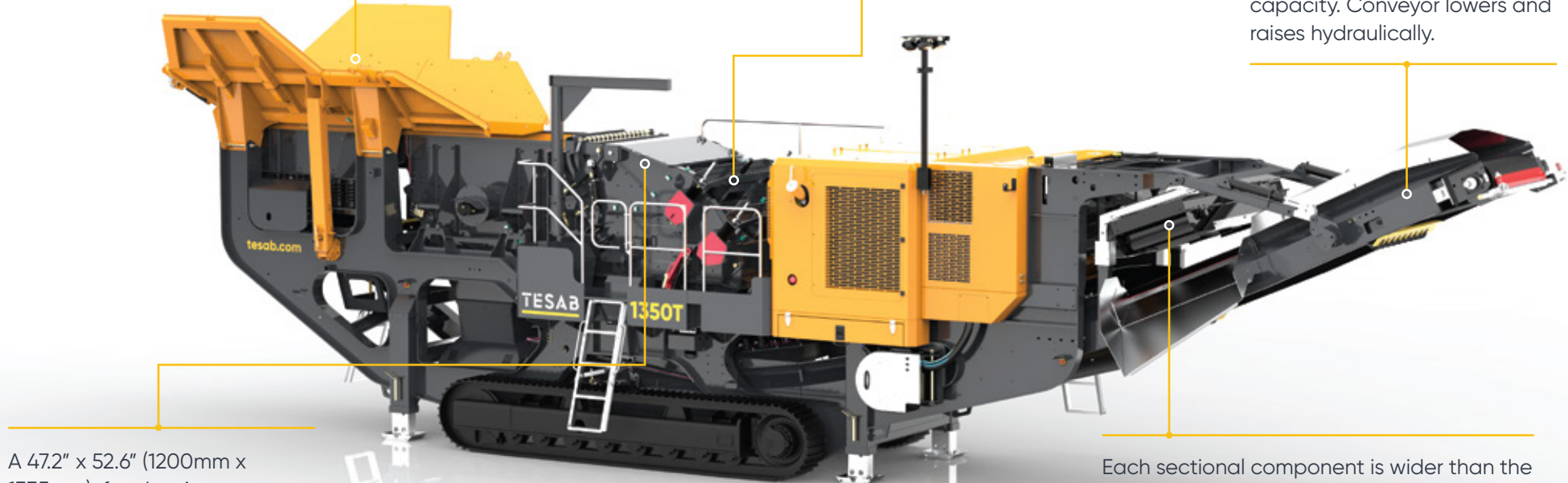

A 47.2" x 52.6" (1200mm x 1335mm), four bar impactor rotor with a 53.5" x 37" (1360mm x 950mm) feed opening.

Each sectional component is wider than the last to allow an unrestricted flow of material without narrowing. Allows for reduced wear and eliminates material bridging.

PERFORMANCE SPECIFICATION

* Depending on application

Engine	Weight - w/ magnet & side conveyor	Impact Rotor	Production Rate*
510 Hp (380 kW)	116,624 lb (52,900kg)	47.2" diameter x 52.6" wide	up to 500 TPH

DIMENSION SPECIFICATION*

* Depending on material density and set-up

TRANSPORT DIMENSIONS			STOCKPILE HEIGHT	
Height	Width	Length	Main Conveyor	Side Conveyor
11' 9.7" (3.60m)	9' 10" (3.0m)	52' 0.3" (15.857m)	13' 8.9" (4.188m)	8' 5.1" (2.57m)

tesab.com